

**The
Vibratory Stress Relief
Library**

REPRINT:

**REDUCTION OF RESIDUAL STRESS
BY ULTRASONIC SURFACE VIBRATION**

**Seiji Hirai
Shigeru Aoki**

**Published in the Japanese Society
of Mechanical Engineers**

1995

Reduction of Residual Stress by Ultrasonic Surface Vibration

Seiji Hirai* and Shigeru Aoki**

* Department of Manufacturing Engineering, Faculty of Practical Engineering, Institute of Technologists, Maeya 333, Gyoda-city, Saitama Pref., 361-0038, Japan

** Department of Mechanical Engineering, Tokyo Metropolitan College of Technology, 1-10-40, Higashi-Ohi, Shinagawa-ku, Tokyo, 140-0011, Japan

Abstract

A new method is proposed for reduction of residual stress by adding ultrasonic surface vibration during welding. The proposed method is examined by butt-welding of thin plates and repair welding of thick plate (for press die) experimentally. From these experiments, the proposed method is effective to reduction of residual stress on and near the bead. The reason for the results is that ultrasonic surface vibration in solid metal transfers better than that of low frequency surface vibration. The proposed method is also examined by theoretically using an analytical model considering plastic deformation. From this analysis, effectiveness of the proposed method is demonstrated.

Keywords: Welding, Ultrasonic vibration, Residual stress, X ray diffraction method, Butt-welding, Repair welding

1. INTRODUCTION

Welding is widely used for construction of many structures. Since welding is a process using locally given heat, residual stress is generated near the bead, tensile residual stress degrades fatigue strength (ASM 1983(1), Donko 1983(2)). Some reduction methods of residual stress are presented (Gnirss 1988(3), Hassen and Tholen 1978(4)). For instance, heat treatment and shot peening are practically used. However, those methods need special equipment and consume much time.

In this paper, a new method is proposed for reduction of residual stress by adding ultrasonic surface vibration during welding and the effectiveness of the proposed method is proved experimentally and theoretically. First, this method is applied to butt-welding of thin plates experimentally. Next, the proposed method is applied to welding of thick plate (for press die) experimentally. In these cases, tensile residual stress on the bead is significantly reduced. Tensile residual stress near the bead is also reduced. Finally, the proposed method is examined theoretically. Since yield force just after welding is very low, it can be considered that reduction of residual stress is caused by plastic deformation. Using analytical model considering plastic deformation, residual stress near the bead is calculated.

2. WELDING EXPERIMENT

2.1 Preliminary Experiment

First, in order to simulate butt-welding of thin plates under simple condition of residual stress, reduction of residual stress is examined by using a specimen with a groove at the center. Size and shape are shown in Fig.1. In this case, residual stress in the direction of thickness is uniform. The specimen is supported on the holding

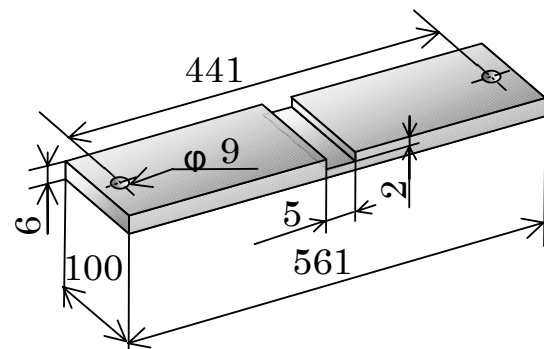

Fig.1 Size of specimen with groove

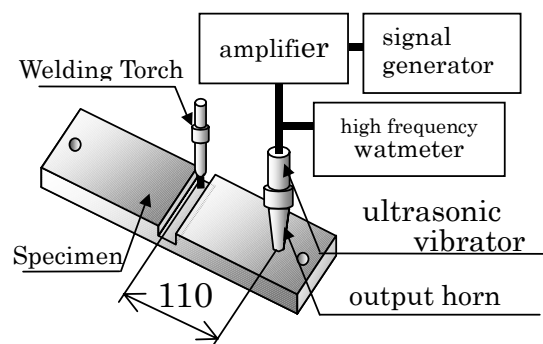

Fig.2 Experimental setup for butt-welding

device and welded along the groove using an automatic CO₂ gas shielded arc-welding machine. Figure 2 shows experimental set-up. Welding is completed through one pass. Material of specimen is rolled steel for general structure (JIS SS400). In order to eliminate residual

Table 1 Conditions for X-ray measurement

Characteristics X-rays	Cr-K α
Diffraction plane	α -Fe(211)
Filter	Vanadium foil
Stress determination	$\sin^2\psi$ method
Irradiated area	2x4mm ²
Tube voltage and current	30kV, 8mA
Scan condition of 2 θ	Step scanning
Divergence angle shift	1.0°
Peak determination	Half value width method

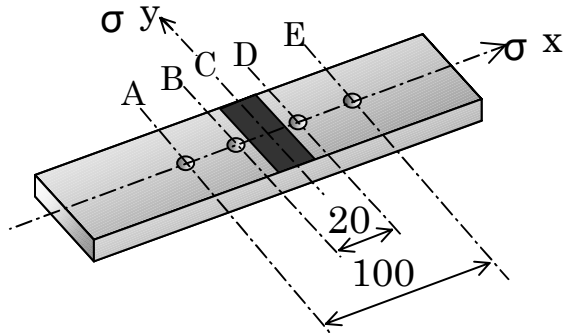

Fig.3 Measuring locations of residual stress

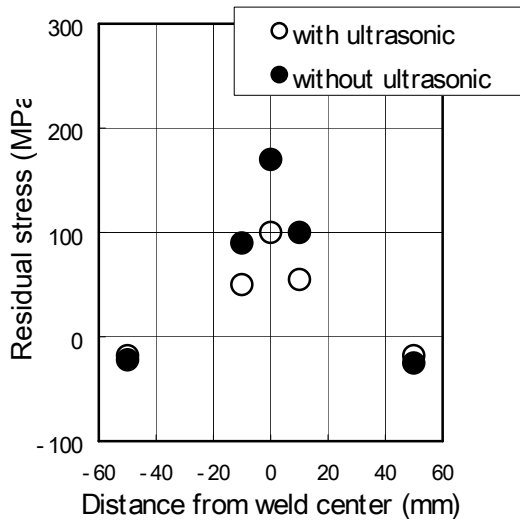

Fig.4 Residual stress of specimen with groove

stress induced by rolling, the specimen is annealed at 800°C for one hour and cooled in a furnace to 200°C. Diameter of the wire is 1.2mm. The applied voltage is 25V and current is 200A. The velocity of welding is 30cm/min. The specimen is shaken at the point 110mm from the center of the groove by ultrasonic surface vibration during welding. Frequency of surface vibration is 17.8kHz. A wide band amplifier amplifies the signal from the frequency synthesizer. Ultrasonic surface vibration is applied by an exponential ultrasonic vibration horn.

Residual stress is measured by removing the quenched scale chemically and using paralleled beam

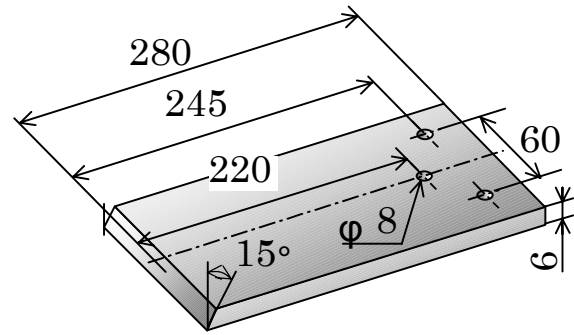

Fig.5 Size of specimen for butt-welding

X-ray diffract meter with a scintillation counter. The X-ray stress measurement conditions are shown in Table 1. Figure 3 shows measuring locations of residual stress. Five locations at the center of the specimen are selected. Stresses in the direction of the bead are measured. Point C is on the bead. Points A and E are 50mm from the bead. Points B and D are 10mm from the bead.

Figure 4 shows the results of residual stress. Symbols ● are the results for the specimen without surface vibration and symbols ○ are results with surface vibration. On the bead, point C, tensile residual stress is significantly reduced when ultrasonic surface vibration is applied during welding. At points B and D, tensile residual stress is also reduced. At points A and E, the compressive residual stress is almost same value.

2.2 Welding of two plates and thick plate

Figure 5 shows the size of specimen for butt-welded. Two plates are hold onto the supporting devices and shaken by ultrasonic surface vibration during welding. One pass welding is performed in V-shaped groove. The root opening is 1mm and the groove angle is 30 degree. Welding conditions are same as the preliminary experiment. Measuring locations of residual stress are shown in Fig.3. Figure 6 shows the results of residual stress. On the bead, point C, tensile residual stress is significantly reduced when ultrasonic surface vibration is applied during welding. At points B and D, tensile

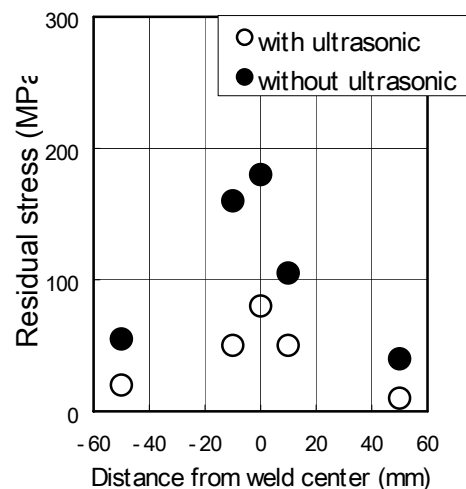

Fig.6 Residual stress of butt-welded specimen

residual stress is also reduced. At points A and D, the tensile residual stress is almost same value.

Next, the proposed method is applied to welding of thick plate. The experiment simulates repair welding of press die. Figure 7 shows the size of specimen. The specimen has a groove 150mm long, 5mm wide and 2mm deep at the center. Figure 8 shows the experimental setup. The specimen is shaken by ultrasonic surface vibration at the fixed point at the center of specimen, 35mm from the one end of groove. The specimen is welded along the groove. Welding is completed in one pass. The velocity is 30cm/min. Measuring locations of

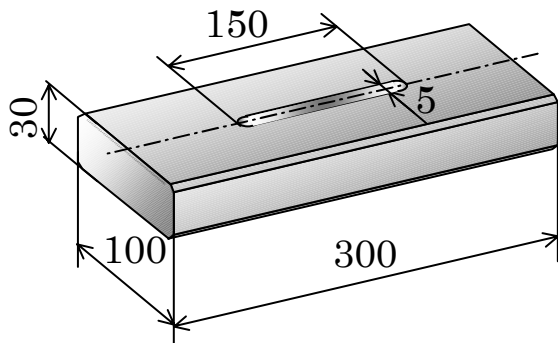

Fig.7 Size of thick plate

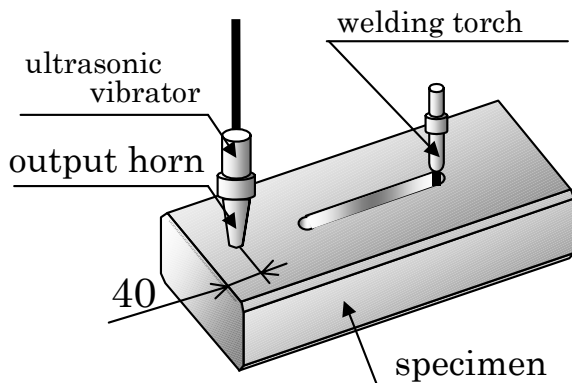

Fig.8 Experimental setup for welding of thick plate

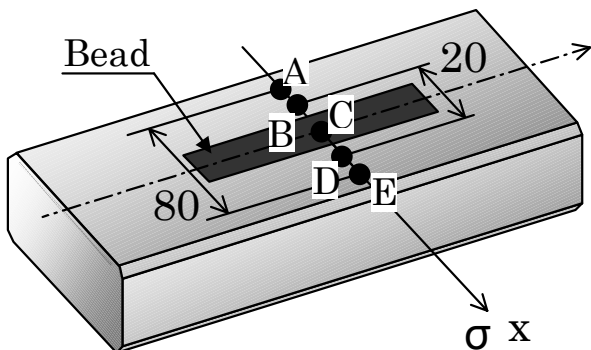

Fig.9 Measuring locations of residual stress of thick plate

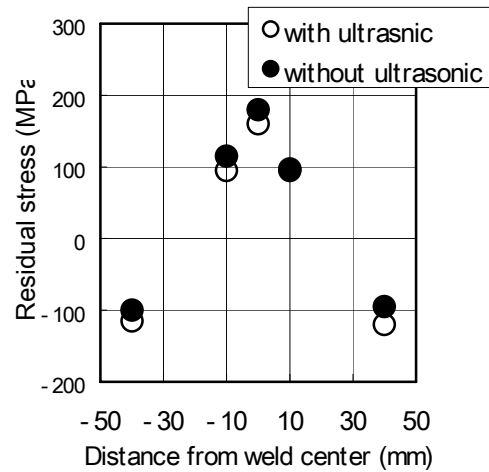

Fig.10 Residual stress of thick plate

residual stress are shown in Fig.9. Point C is on the bead. Points A and E are 40mm from the bead. Points B and D are 10mm from the bead. Figure 10 shows the results of residual stress. Symbols ● are the results for the specimen without surface vibration and symbols ○ are results with surface vibration. On the bead, point C, tensile residual stress is reduced when ultrasonic surface vibration is applied during welding. At points B and D, tensile residual stress is also reduced. At points A and E, the compressive residual stress is almost same.

From these results, it can be seen that tensile residual stress on and near the bead of welded thick plate are reduced when the specimens are shaken by ultrasonic surface vibration during welding.

3. ANALYTICAL METHOD

3.1 Analytical Model

Yield stress of metal immediately after welding is very low. It is considered that permanent deformation can be generated by very low external load. In this analysis, reduction of tensile residual stress on the bead of thin plate is dealt with using two-dimensional model. Since specimens are thin plates, plane stress state is considered. Hence, an analytical model shown in Fig.11 ($Z_e=0$) is used considering actual stresses in plane. x-axis is longitudinal direction of the specimen, direction of surface vibration, and y-axis is transverse direction of the specimen, direction of the bead. As shown in Fig.11 ($Z_e>0$), springs in transverse direction are extended by Z_e from the equilibrium position. In this case, $k_y Z_e$ is initial residual stress. It is assumed that restoring force-deformation relation of the springs is represented by the perfectly-elasto-plastic model. Accordingly, when stresses in x-axis and y-axis are considered to be principal stresses, it is assumed that springs are yielding according to Tresca yield criterion as shown in Fig.12. This model is excited in x-axis. Equation of motion in the elastic range is expressed as:

$$m \ddot{x} + 2k_x (x - u - Z_{px}) = 0 \quad (1)$$

where Z_{px} is permanent displacement of springs in x-axis. Equation of motion for relative displacement $z(=x-u)$ is written as:

$$m\ddot{x} + 2k_x(z - Z_{px}) = -m\ddot{u} \quad (2)$$

Z_{fx} is defined as yield displacement. When springs in x-axis are subjected to tensile stress and are yielding, $z - Z_{px} > Z_{fx}$, $\ddot{x} > 0$, equation of motion is,

$$m\ddot{x} + 2F_x = -m\ddot{u} \quad (3)$$

where F_x is yield force in x-axis. Permanent displacement is given as:

$$Z_{px} = Z_{pr} - Z_{fx} \quad (4)$$

where Z_{pr} is displacement when \ddot{x} becomes 0 to negative. Then, Eq.(1) for elastic range is used. In the case where springs in x-axis are yielding when springs are subjected to compressive stress, yield force change as residual stress σ_{sy} changes. When $z - Z_{px} < Z_{ff}$, where Z_{ff} is yield displacement, and $\ddot{x} < 0$, equation of motion is written as:

$$m\ddot{x} - 2(F_x - \sigma_{sy}) = -m\ddot{u} \quad (5)$$

where Z_{ff} is given as:

$$Z_{ff} = (\sigma_{sy} - F_x) / \omega_s^2 \quad (6)$$

ω_s is initial natural circular frequency and initial σ_{sy} is $k_y Z_e$. Permanent displacement is given as:

$$Z_{px} = Z_{mr} + Z_{fx} \quad (7)$$

where Z_{mr} is displacement when \ddot{x} becomes 0 to positive. Then, Eq.(1) for elastic range is used.

It is assumed that length of plastic area in the direction of the bead is equal to width of the bead and volume of plastic area is constant. Then, sum of plastic deformation in y-axis Z_{py} is given as:

$$Z_{py} = 0.5Z_{px} \quad (8)$$

Residual stress with surface vibration is evaluated as:

$$\sigma_{sy} = k_y(Z_e - Z_{py}) \quad (9)$$

Residual stress is considered to be reduced through the pass shown in Fig.12.

3.2 Results of Analysis

Excitation term \ddot{u} is given as $\ddot{u} = U \sin \omega t$ in equation of motion. The natural frequency of the specimen in elastic range is defined as $f_n = \omega_n / 2\pi = \sqrt{2k_x / m}$. The natural frequency within elastic limit f_n changes as the length of the bead increases. Table 2 shows relation between the length of the bead L_w and the natural frequency f_n calculated using beam element model. When $L_w \geq 10\text{mm}$, f_n becomes constant value 95Hz. f_n is approximately given as:

$$f_n \begin{cases} 60 + 3.5L_w \text{ (Hz)} : 0 \leq L_w < 10\text{mm} \\ 95 \text{ (Hz)} : 10 \leq L_w \leq 100\text{mm} \end{cases} \quad (10)$$

Table 3 shows ratio of residual stress with surface vibration σ_{sy} to that without surface vibration σ_{yi} for some values of F_e / mU and σ_{yi} / F_e . Excitation frequency is 17.8kHz. From this table, reduction rate of residual stress increases as σ_{yi} / F_e tends to be 1, that is, residual stress before shaking approaches to yield force.

4. CONCLUSIONS

From welding experiments, it is found that tensile residual stress near the bead is reduced when the specimen is shaken by ultrasonic surface vibration during welding. The proposed method is examined by analytical

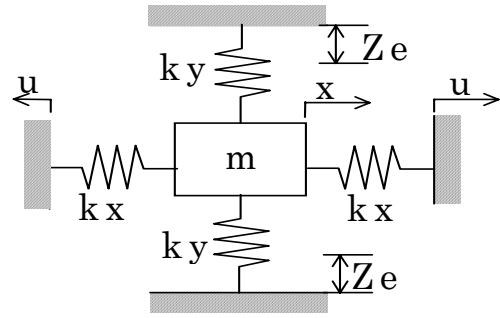

Fig.11 Analytical model

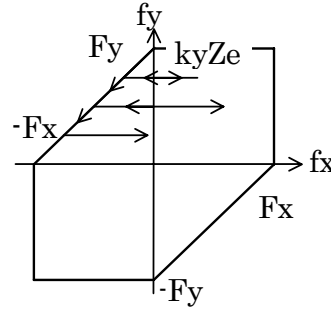

Fig.12 Tresca yield criterion

Table 2 Length of bead and natural frequency of specimen

$L_w(\text{mm})$	0.01	0.1	1	5
$f_n(\text{Hz})$	60.2	64.7	81.3	91.0

Table 3 Ratio of residual stress with and without ultrasonic surface vibration

σ_{yi} / F_e	F_e / mU				
	0.002	0.003	0.004	0.005	0.006
0.9	0.13	0.46	0.62	0.71	0.78
0.8	0.14	0.49	0.67	0.77	0.83
0.7	0.15	0.53	0.71	0.82	0.89

method. Using two-dimensional model with preloaded springs having elasto-plastic force-deformation relation, effectiveness of the proposed method is proved.

REFERENCES

- (1) American Society of Metals, Metals Handbook, pp.856-895, 1983
- (2) Donko, J.C., "A Review of Weld Residual Stresses in Austenitic Stainless Steel Piping. - Recent Trends in Welding Science and Technology -", Proceedings of the 2nd International Conference on Trends in Welding Research, ASM International, Materials Park, OH, pp.113-118, 1989
- (3) Gnirss, G., "Vibration and Vibratory Stress Relief. Historical Development, Theory and Practical Application", Welding in the World, Vol.26, No.11/12, pp.4-8, 1988
- (4) Hassen, I. and Tholen, A., "Plasticity due to Superimposed Macrosonic and Static Strains", Ultrasonics, March, pp.7-64., 1978